

## Features

Compact, High-efficiency

Universal Input:  
90~264V AC (120~430V DC)

Operating altitude: up to 5,000m

Operating temp: -30°C to +70°C

Low leakage current:  
<0.5mA @ 240V AC

Approved to CE, CCC, RoHS,  
REACH\*

## 10PLS-35-XX

35W Enclosed AC/DC Power Supply



The 10PLS-35-XX flat-panel power supply offers a 31mm ultra-thin profile, universal AC input, and natural convection cooling for efficient thermal performance. It supports operation from -30°C to +70°C and provides high isolation, reliable performance, and a compact lightweight design. Safety and EMC specifications align with international standards including EN IEC 62368-1 and GB 4943.1. Suitable applications include industrial control, energy storage, charging infrastructure, LED systems, security, telecommunications, and smart home equipment.

## Models

Model Number	Input Voltage (V)	Output Voltage (V DC)	Output Voltage Range (V DC)	Output Current (A)	Rated Power (W)	Efficiency (%)	Ripple & Noise(max.) (mVp-p)
10PLS-35-5*	90~264V AC 120~430V DC	5	4.5~5.5	7	35	86	100
10PLS-35-12		12	10.2~13.8	3	36	87	150
10PLS-35-15*		15	13.5~18	2.4	36	87	150
10PLS-35-24		24	21.6~28.8	1.5	36	88	200
10PLS-35-36*		36	32.4~39.6	1	36	88	200
10PLS-35-48*		48	43.2~52.8	0.8	38.4	89	200
10PLS-35-54*		54	49.1~59.4	0.67	36	89	200

\*5V, 15V, 36V, 48V & 54V models not yet certified

Input Specifications	
Parameter	Specification
Rated input voltage	100~240V AC
Input voltage range	90~264V AC (120~430V DC)
Rated input frequency	50~60 Hz
Input frequency range	47~63 Hz
Input current	0.8A Typ. @ 115V AC, 1A Typ. @ 230V AC
Maximum surge current	Cold start, 50A type / 230V AC
Leakage current	< 0.5mA @ 240V AC

Output Specifications	
Parameter	Specification
Output Connector	Screw terminal
Line Regulation	±0.5% Max
Load Regulation	±0.5% Max
Rise time	50 ms Typ. @ 115V AC & 230V AC
Available machine time	1500 ms Typ. @ 115V AC & 230V AC
Hold-up time	12ms Typ. @ 115V AC, 12ms Typ. @ 230V AC
Capacitive load startup (Max)	<b>5V:</b> 8,000 µF Max, <b>12V:</b> 4,000 µF Max, <b>15V:</b> 3,000 µF Max, <b>24V:</b> 2,000 µF Max, <b>36V:</b> 1,000 µF Max, <b>48V:</b> 1,000 µF Max, <b>54V:</b> 1,000 µF Max

Environmental Characteristics		
Parameter	Condition	Specification
Ambient temperature	Operating	-30°C to +70°C (cold start at -40°C)
Ambient temperature	Storage	-40°C to +85°C
Power derating	Temperature	Power derating by 2% per °C above 50°C
Power derating	Voltage	<115V AC power derating: 0.6% per volt (80% load @ 90V AC)
Operating humidity	—	20 to 90% RH (no condensation)
Operating altitude	—	0 to 5,000m (0 to 16,400 ft)
Impact test	Non-operational	IEC 60068-2-27, half-sine wave: 50G for 11ms; 3 times in each direction, totalling 9 times
Impact test	Operational	IEC 60068-2-27, half-sine wave: 10G for 11ms; X-axis 1 cycle
Vibration test	Non-operational	IEC 60068-2-6, random: 5Hz~500 Hz (2.09G); 20 minutes in all X, Y & Z
Vibration test	Operational	IEC 60068-2-6, sine wave: 10Hz~500 Hz @ 19.6 m/s <sup>2</sup> (2G peak); 10 minutes 1 cycle, X direction 60 minutes
Overvoltage category	—	II (compliant with EN 62477-1 OVC III standard for 2000-meter altitude elevation)

Protection	
Parameter	Specification
Overvoltage	<b>5V:</b> <6.3V, <b>12V:</b> <16.2V, <b>15V:</b> <21.75V, <b>24V:</b> <33.6V, <b>36V:</b> <45V, <b>48V:</b> <60V, <b>54V:</b> <63V
Overload / Overcurrent	110~150% rated load current, hiccups mode, non-lockout (automatic recovery)
Over Temperature	Automatic recovery
Short Circuit	Hiccups mode, unlocked (automatically restored after fault resolution)
Electrical Shock	Connect PE*4 to achieve Class I

Reliability Requirements	
Parameter	Specification
MTBF	Telcordia SR-332: > 700,000hrs, Input: 115V AC & 230V AC, Output: 100% load, Temperature: 25°C
Warranty	3 years

Regulatory Compliance	
Parameter	Specification
Safety Entry Low Voltage	Safety Entry Low Voltage — SELV
Approvals	CE, CCC, RoHS, REACH (5V, 15V, 36V, 48V & 54V TBC)
Standards	EN IEC 62368-1, GB 4943.1
Isolation Voltage	Input~Output: 4000V AC
	Input~Ground: 2000V AC
	Output~Ground: 1250V AC

EMC	
Parameter	Specification
EMC Standards	EN 55032 + A11 + A1, EN 55035 + A11, EN IEC 61000-3-2 + A1, EN 61000-3-3 + A1 + A2
Electrostatic Discharge	IEC 61000-4-2: Level 4 Criteria A1, Air discharge: 15kV: Contact discharge: 8kV
Radiated Immunity	IEC 61000-4-3: Level 3, Criteria A1, 80MHz~1GHz, 10V/m, 1kHz, 80% modulation
EFT/Burst	IEC 61000-4-4: Level 3, Criteria A1, $\pm 2$ kV
Surge Immunity	IEC 61000-4-5: Level 4, Criteria A1, Common mode 4: $\pm 4$ kV, Differential mode 5: $\pm 2$ kV
Conducted Immunity	IEC 61000-4-6: Level 3, Criteria A1, 150kHz~80MHz, 10 Vrms
Magnetic Field Immunity	IEC 61000-4-8: Level 4, Criteria A1, 30A/meter
Voltage Dips & Interruptions	IEC 61000-4-11: 0% sudden drop:1 cycle, Criteria B2: 40% sudden drop 10 cycles, Criteria C3: 70% sudden drop 25 cycles
Harmonic Current	IEC/EN/BS EN 61000-3-2: Class A

Product Details	
Parameter	Specification
Shell base	Aluminium
Outer cover of housing	SGCC
Size (L x W x H)	99 x 82 x 31 mm
Weight	0.2kg
Pilot lamp	Green LED (DC OK)
Cooling method	Natural convection
Wire	AWG 18–12 (refer to AWG table on next page)
Noise	Sound Pressure Level (SPL) < 30dBA (1 meter from the power supply)

**Assembly & Installation**

AWG Wire Table

PVC wire AWG rated current			
6 AWG	52.5 A	20 AWG	6.5 A
8 AWG	37.5 A	22 AWG	5.0 A
10 AWG	29.0 A	24 AWG	3.5 A
12 AWG	22.5 A	26 AWG	2.5 A
14 AWG	16.5 A	28 AWG	2.0 A
16 AWG	12.0 A	30 AWG	1.5 A
18 AWG	9.0 A		

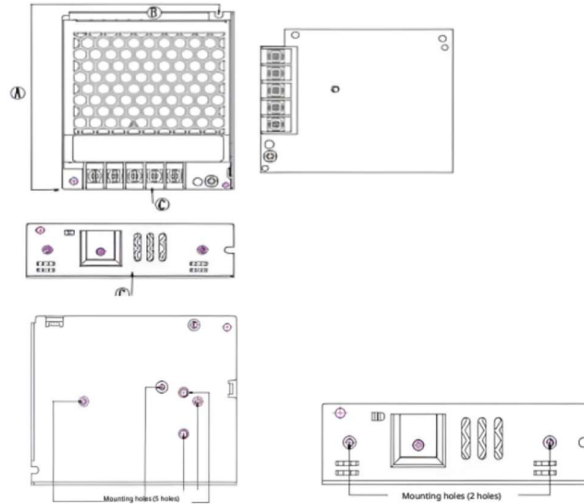
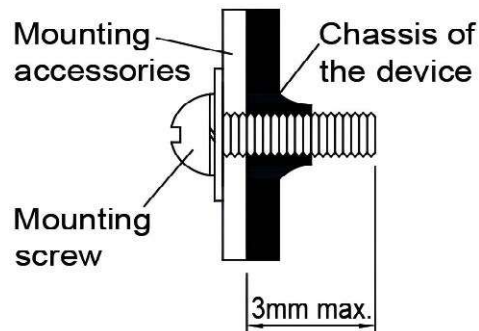

**Installation Instructions:**

Only M3 screws with a diameter  $\leq 3$  mm (0.20 inch) are permitted for installation through base drilling to ensure secure fastening of screws to internal components.

Maintain a safe distance  
 Recommended installation tightening torque:  
 4~7Kgf.cm (3.47~6.08lbf.in)

1. If you use the power supply in a non-recommended installation direction, please contact Ideal Power for consultation.
2. Ensure adequate convective cooling. When the power supply is in operation, all external components must maintain a safety distance of  $\geq 50$ mm (1.97 inch) from the power supply ventilation surface.
3. It is not recommended to install power supplies on surfaces with low thermal conductivity coefficients, such as plastics.
4. Note: The power supply enclosure may overheat depending on ambient temperature and power load. Avoid contact during operation or immediately after shutdown to prevent burns!
5. Do not touch the terminal block under power supply conditions to avoid electric shock.
6. During installation, it is imperative to ensure that no external metals, objects, or conductors enter the power supply to prevent electric shocks, safety hazards, fires, or machine operational failures.
7. The power supply must be installed on a grounded metal surface using metal screws. It is strongly recommended to connect the grounding terminals of the power supply terminal block to the earth.

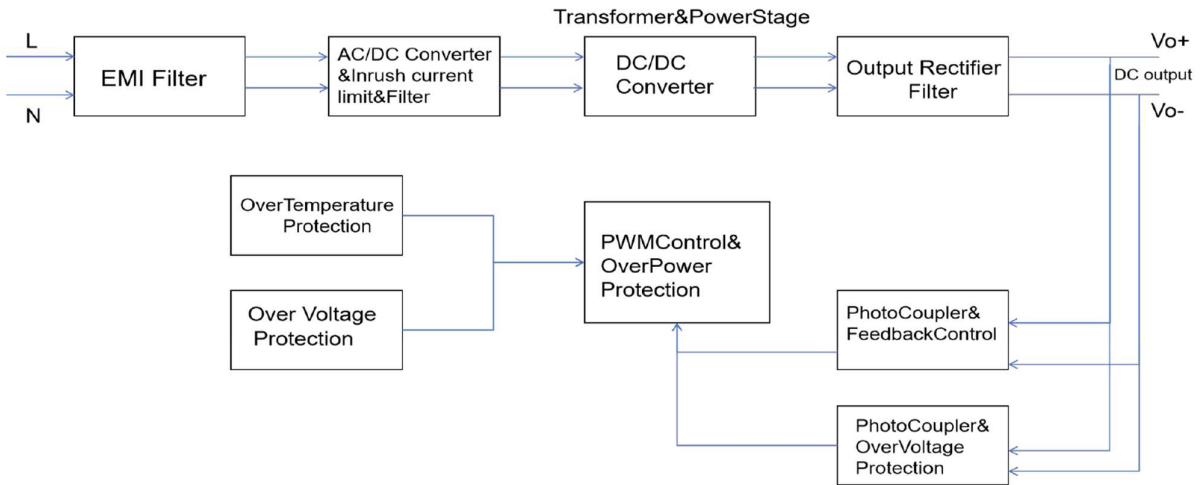
Block Diagram



Power Supply Component Description

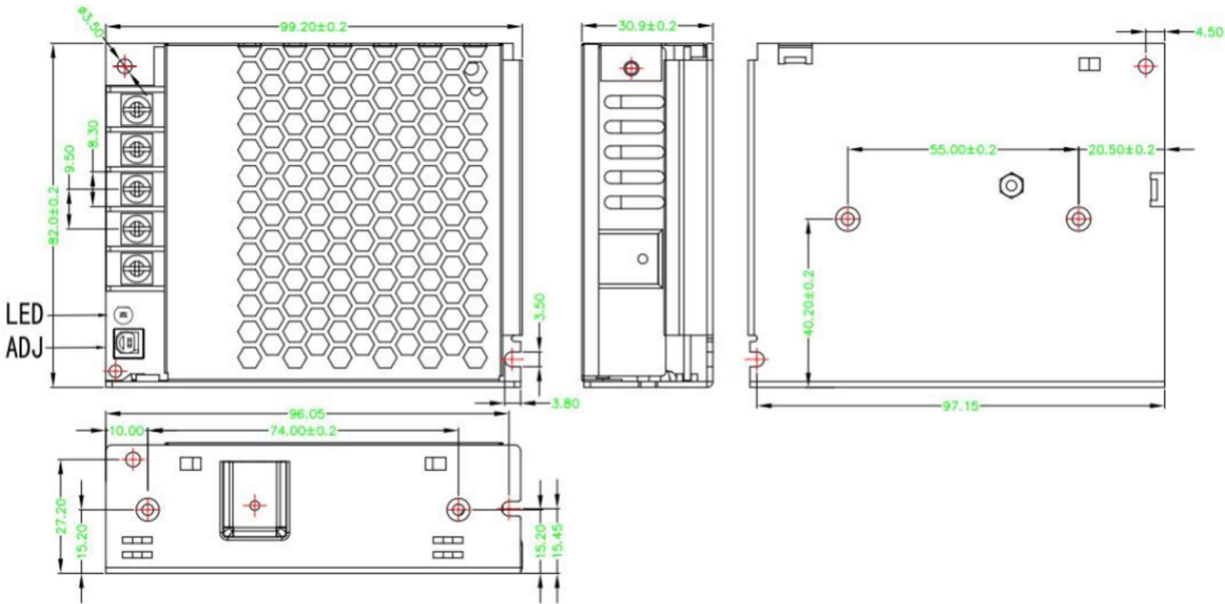

Pin configuration		Installation site	Screw specifications	L (Max)
Foot	function	② - ④	M3	3.0MM
1	AC (L)	⑤ - ⑦	M3	3.0MM
2	AC (N)			
3	⊕			
4	-Vo			
5	+Vo	① - ⑧		Grounding is required

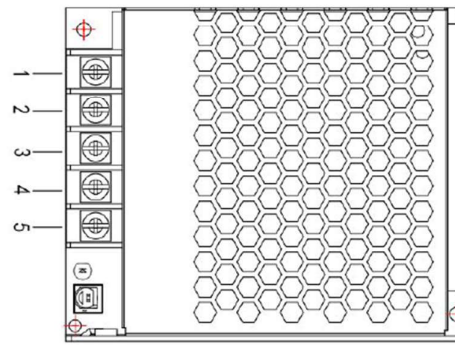
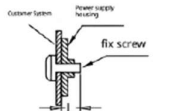

Unless otherwise specified, the dimensional tolerance is  $\pm 0.5$ .

Engineering Data

Figure 1) Temperature Derating / Output Load Derating Corresponding to Ambient Temperature

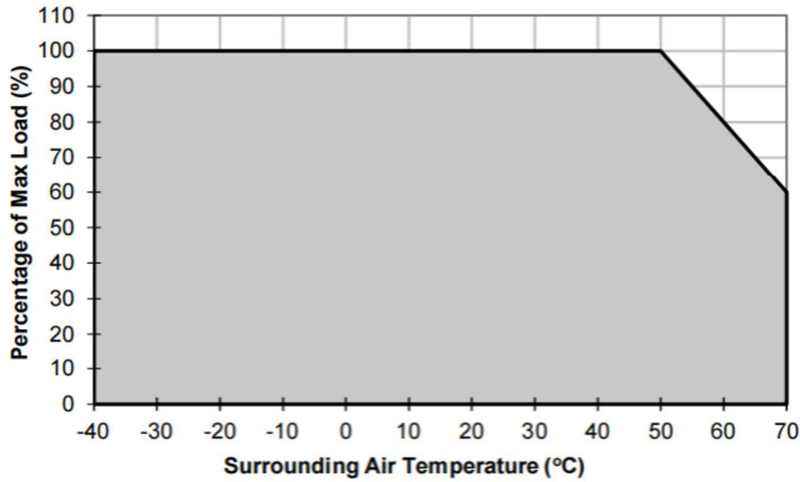
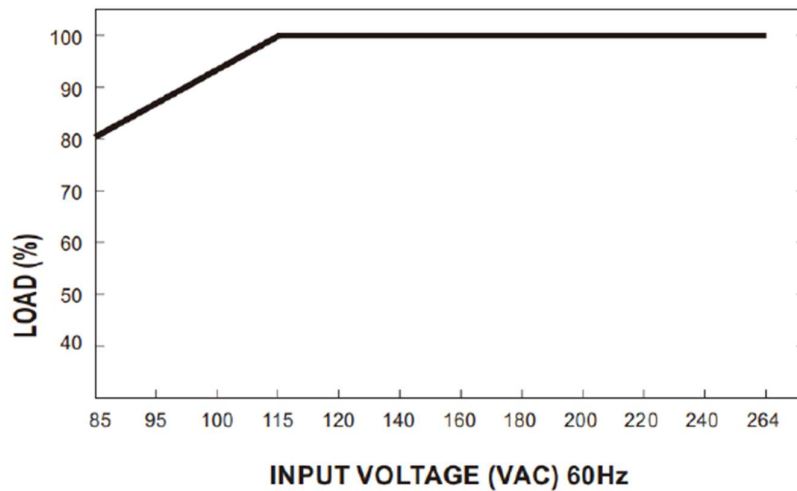

Figure 2) AC Input Voltage Derating / Output Load Derating Versus Input Voltage



1. If the power supply is continuously operated outside the rated power curve, it may lead to component degradation or damage, as shown in Figures 1 and 2.
2. When the ambient temperature is below -30°C, the PSU may enter a hiccupping state upon startup, but the startup duration should not exceed 5 seconds.
3. When the ambient temperature exceeds 50°C, the power supply will activate overtemperature protection if the output power is not reduced. Once activated, the power supply protector will operate intermittently until the ambient temperature decreases or the load returns to its normal operating state. To restart, the input AC voltage must be released or reset.
4. To ensure proper functioning, the power supply must maintain a safe distance from other equipment during operation, as specified in the Safety Guidelines section.
5. Note: Depending on the ambient temperature and the load connected to the power supply, the power supply may overheat.

Function

Figure 1) Diagram of Turn-on Time, Rise Time, and Hold Time

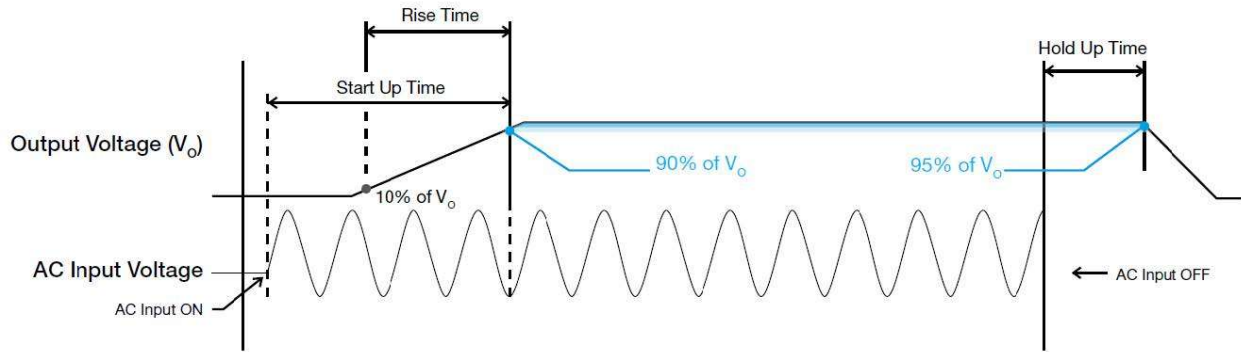

**Available Machine Time:**

The time required for the output voltage to rise to 90% of the rated value after the input voltage is applied.

**Rise Time:**

The time required for the output voltage to change from 10% to 90% of its final steady-state value.

**Retention Time:**

The time interval between the interruption of the AC input voltage and the output voltage dropping below 95% of its final steady-state value.

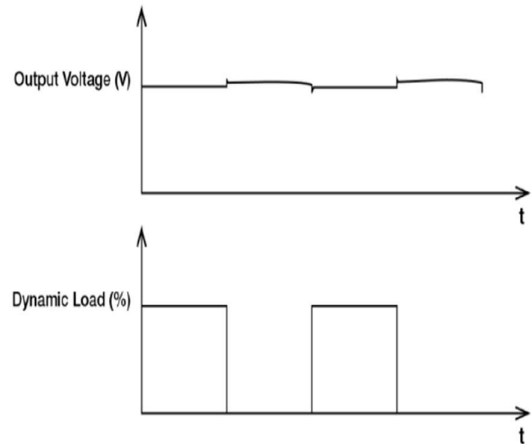
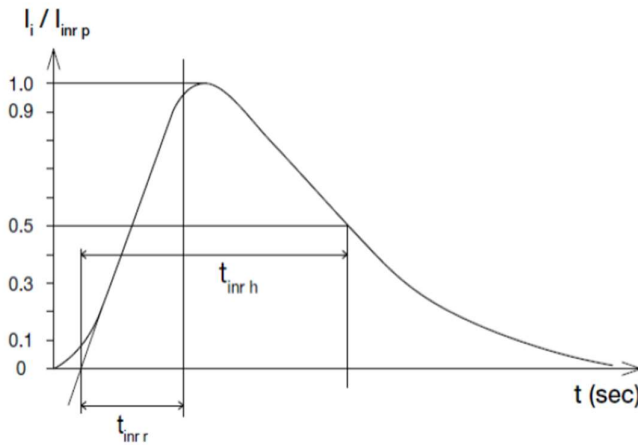

**Surge Current**

Surge current refers to the instantaneous peak current generated upon the activation of the input voltage. Under AC input voltage, the maximum surge current occurs during the upper half-cycle of the AC voltage, with its peak value declining exponentially in subsequent cycles.

**Overload and overcurrent protection (automatic recovery)**

When the output current exceeds 110% of  $I_o$  (maximum load), the power supply's overload (OLP) and overcurrent (OCP) protection mechanisms are triggered. In this scenario,  $V_o$  begins to decrease; once the power supply reaches its maximum power limit, the protection is activated, and the power supply enters "hiccup mode" (automatic recovery). Once the OLP or OCP failure is resolved and  $I_o$  returns to the normal range, power can be restored.

**Dynamic Response**

When the dynamic load varies dynamically from 10% to 100%, the power supply output voltage maintains a stable regulation rate of  $\pm 10\%$ .

**Overvoltage protection (automatic recovery)**

When internal feedback fails, the power overvoltage circuit is triggered, and the output voltage must not exceed the range specified in the "Protection" section. The power supply resumes normal operation after protection and fault resolution.

Function

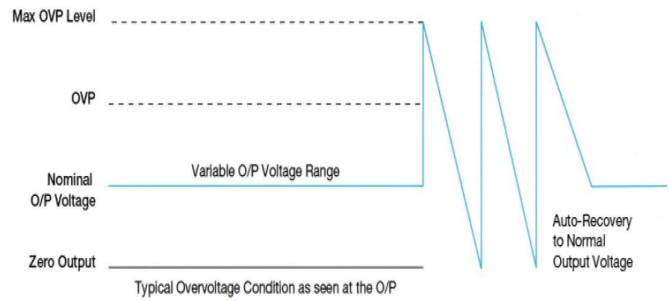
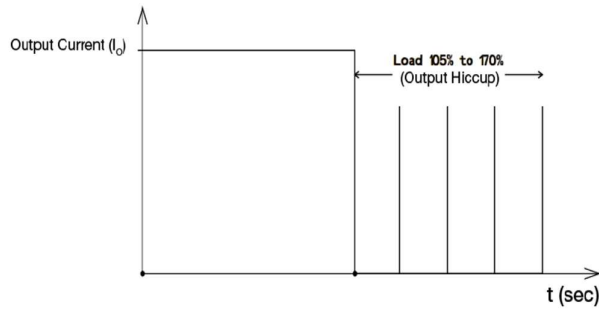

**Short-circuit protection (automatic recovery)**

The OLP/OCP power output function also provides short-circuit protection. During a short circuit, the output current operates in a "hiccup mode," and the power supply returns to normal operation once the short circuit is resolved.

**Overtemperature protection (automatic recovery)**

As described in the Load Derating section, the power supply incorporates overtemperature protection (OTP) functionality. If the operating temperature exceeds the specified limits under 100% load conditions, the OTP circuit is triggered, and the output voltage enters a hiccup mode until the temperature returns to the normal operating range recommended by the derating chart.